

TUBE•LINE™

Tubeline Manufacturing Limited
6455 Reid Woods Drive RR #4
Elmira, Ontario, Canada N3B 2Z3

Email: sales@tubeline.ca

Fax: 519.669.5808

Tel: 519.669.9488

Toll-free (North America): 1.888.856.6613

www.tubeline.ca

Operator's Manual

Keep this manual with the machine at all times.

BF5000S

Stationary Balefeeder

BF5000S

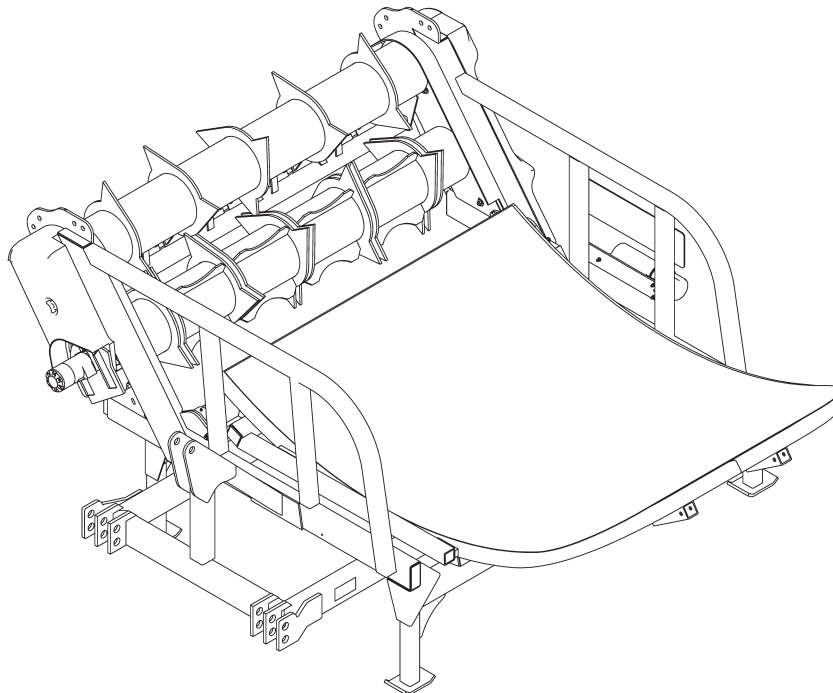

Operator's Manual

Thank you for choosing the Tubeline Chainless Stationary Balefeeder.
Our hope is that it will give you many years of productive service.

Please read and understand this manual and the machine before operation.

Warranty and Limitation of Liability

All equipment is sold subject to mutual agreement that it is warranted by the company to be free from defects of materials and workmanship. But the company shall not be liable for special, indirect or consequential, damages of any kind under this contract or otherwise. The company's liability shall be limited exclusively to replacing or repairing without charge, at its factory or elsewhere, at its discretion.

Any material, or workmanship defects which become apparent within one year from the date on which the equipment was purchased, and the company shall have no liability for damages of any kind. The buyer by the acceptance of the equipment will assume all liability for any damages, which may result from the use or misuse by his employees or others.

Serial Number

The implement serial number is located on the front left side of the frame. This number helps us to track changes and improvements and must be mentioned when ordering parts or requesting service. For your convenience, a space has been provided inside the front cover of this manual to record the serial number, model number, purchase date, and dealer name.

Model No: _____

Serial No: _____

Date Purchased: _____

Dealer Name: _____

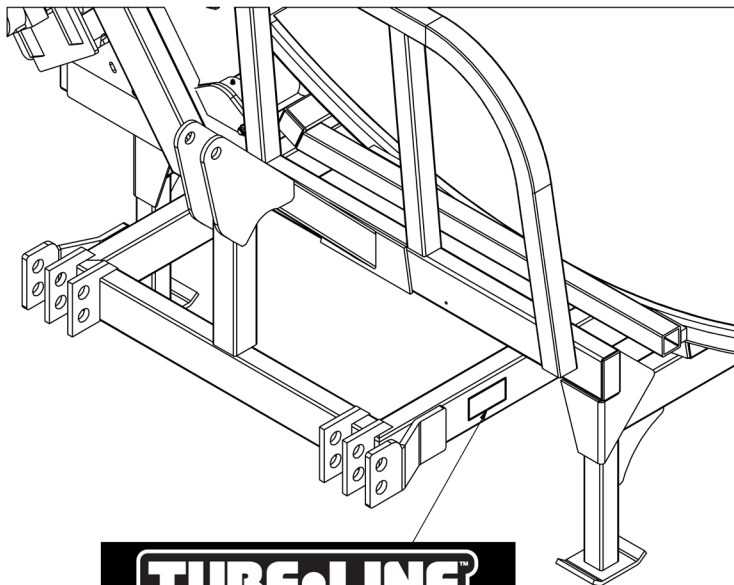

Table of Contents

Operator's Manual	I
Warranty and Limitation of Liability	I
Serial Number	I
Section 1: General Information	1-1
Usage	1-1
Bales	1-1
Power Unit Requirements	1-1
Weight	1-1
Dimensions	1-1
Orientation	1-2
Terminology	1-2
Section 2: Safety	2-1
Safety Signal Words / Safety Messages	2-1
Safety Guidelines	2-1
Personal Protective Equipment	2-2
Hydraulic Safety	2-2
Maintenance Safety	2-2
Decal Locations	2-3
Safety Decals	2-5
Model Decals	2-6
Section 3: Pre-Operation	3-1
Initial Setup	3-1
Optional Bale Bumper Installation	3-1
Optional Bale Extension Installation	3-1
Power Unit Hookup	3-2
Transporting	3-3
Speed Limit	3-3
Section 4: Adjustments	4-1
Beater Guide	4-1
Section 5: Operation	5-1
Loading Bales	5-1
Feeding	5-1
Section 6: Maintenance	6-1
Grease Point - Beater Bearings	6-1
Grease Point - Cylinder Pivot	6-2
Grease Point - Bale Bumper Bearing (if equipped)	6-2
Daily Maintenance	6-3
Preseason Service	6-3
End of Season Service	6-3
Section 7: Troubleshooting	7-1
Round Bale Problems	7-1
Square Bale Problems	7-1

Section 8: Parts Breakdowns & Lists	8-1
Front Chain Drive	.8-2
Rear Chain Drive	.8-4
Beaters	.8-6
Bed	.8-8
Hydraulic Layout	8-10
Section 9: Options	9-1
BF-RBB - Bale Bumper	.9-1
BF-SBEX60 - Bale Extension	.9-3
Torque Values - Imperial	10-1
Torque Values - Metric	11-1

Section 1: General Information

Usage

This machine is designed to unravel round bales in a windrow for feeding livestock. The BF5000S works well with hay, straw, baleage and silage. This machine does not alter material length.

Bales

The BF5000S can handle up to a 5' x 6' round bale. If equipped with optional bale extension this machine can feed square bales **up to 8'** long. Maximum load capacity is 4000lbs.

Power Unit Requirements

The BF5000S requires a power unit with 8-16 GPM feed rate, a minimum of 2000PSI and a 40hp engine.

Weight

The standard BF5000S balefeeder has a shipping weight of 1500lbs (680kg).

Dimensions

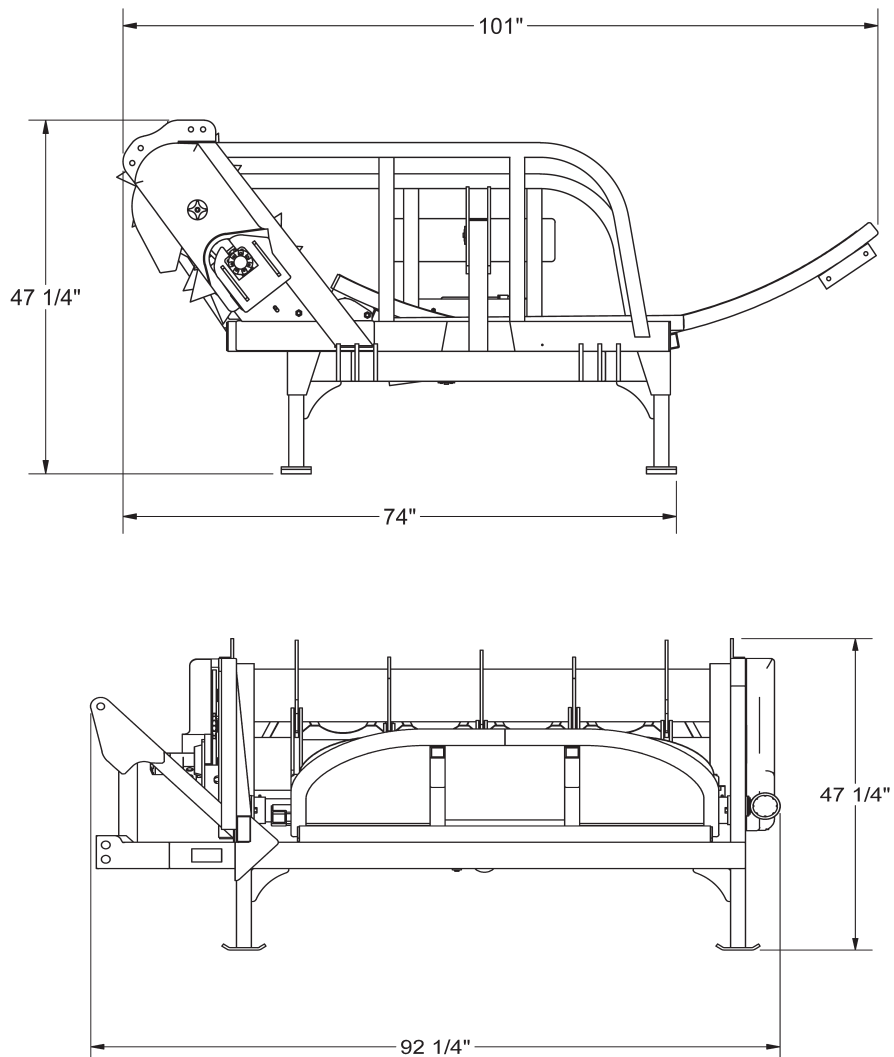

Orientation

Directional references in this manual are dependant on the operator's position from a forward pointed position while towing this machine.

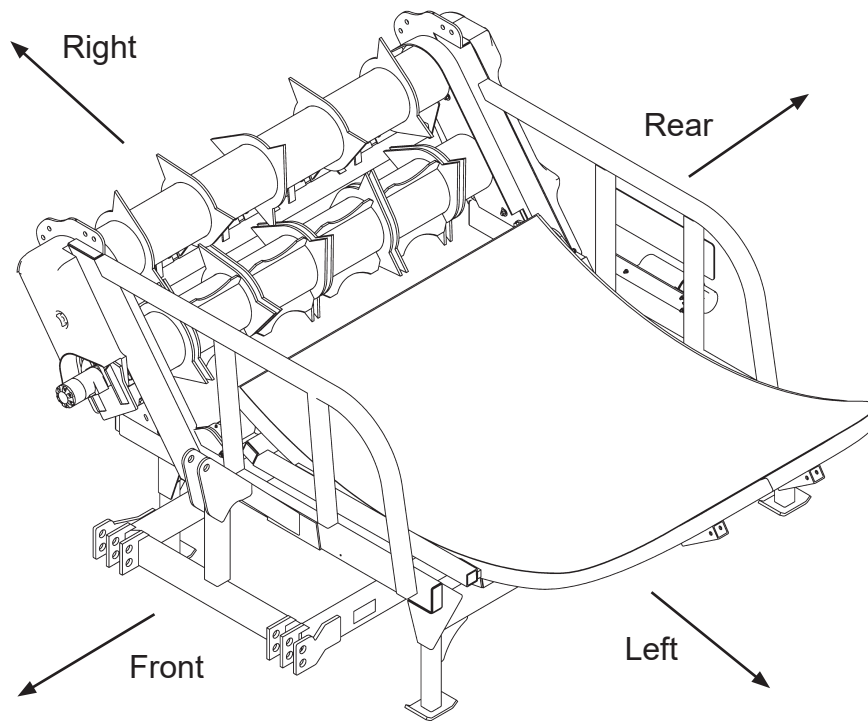

Terminology

Common terms used in this manual.

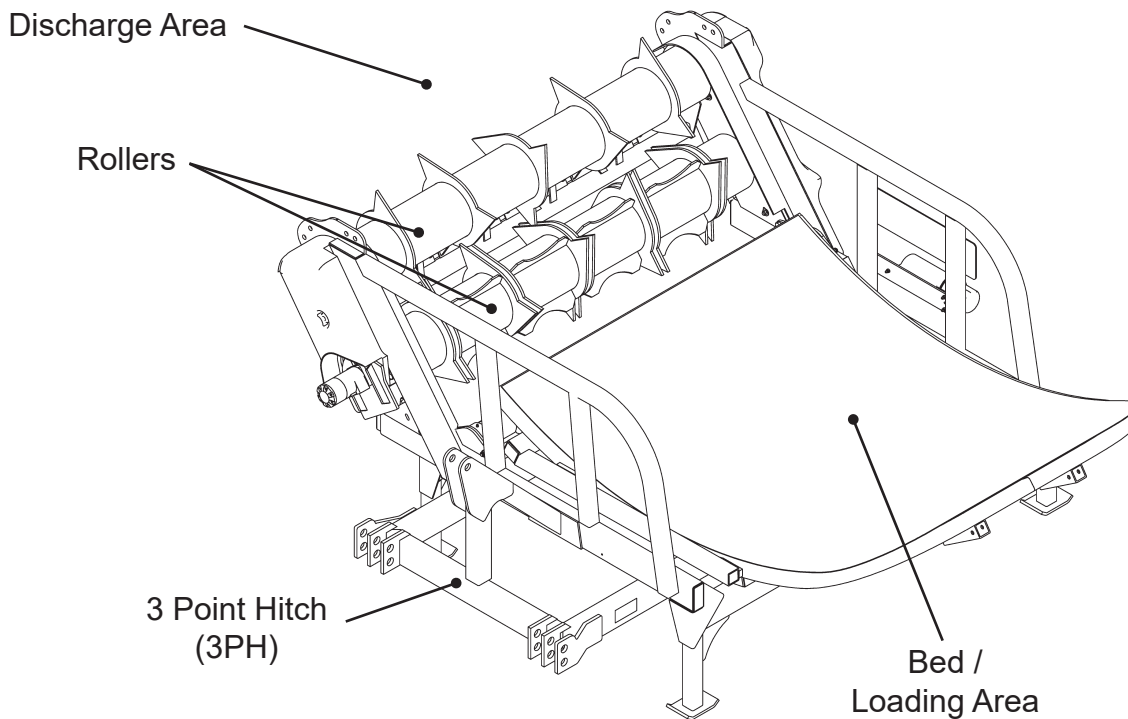

Section 2: Safety

NOTE: This safety alert symbol is found throughout this manual to call attention to instructions involving yourself and others working around the machine.

Failure to follow these instructions can result in injury or death.



This symbol means:

- **Attention!**
- **Become Alert!**
- **Your Safety is involved!**

Safety Signal Words / Safety Messages

CAUTION: Indicates a potentially hazardous situation that may result in injury.

WARNING: Indicates a potentially hazardous situation that could result in serious injury or death.

DANGER: Indicates a hazardous situation that needs to be avoided. Operator needs to be aware of these dangers. High probability of serious injury or death.

NOTE: Indicates an informative non-safety related message.

Safety Guidelines

Take the necessary precautions to avoid injury or death. These include:

- Have training and train new operators.
- Review the safety instructions with all users annually.
- Know where safety decals are and what they convey.
- **DO NOT** paint over, remove or deface any safety signs or warning decals on your equipment.
- Replace damaged and/or missing safety decals.
- **DO NOT** operate without fully installed shields.
- Reinstall any removed shields **BEFORE** operating.
- Inspect machine before operating.
- **DO NOT** operate this machine while under the influence of drugs or alcohol.
- **DO NOT** let children ride or operate this machine.
- Keep a first aid kit and a fire extinguisher on site in case of emergency.

Personal Protective Equipment



WARNING: Wear work boots, gloves, and safety glasses when maintaining or repairing machine.

WARNING: Wear work boots and ear protection when operating machine.

DANGER: Do not wear loose clothing when operating or maintaining the BF5000S.

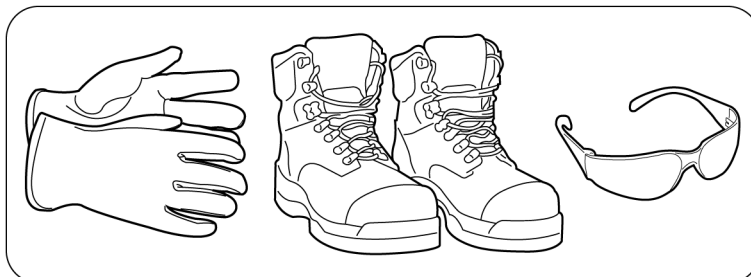

Hydraulic Safety

Before applying pressure to the system, be sure all connections are tight and that hoses and connections are not damaged.

Ensure that all the pressure is released from the hydraulic lines before repairing. Replace or repair damaged hoses immediately.



WARNING

When checking for oil leaks use a piece of cardboard; **DO NOT** use your hand:

- Escaping fluid under pressure can penetrate the skin causing serious injury.
- Avoid the hazard by relieving pressure before disconnecting hydraulic or other lines.
- Tighten all line connections before applying pressure.
- Protect hands and body from high-pressure fluids.

If an accident occurs, see a doctor immediately. Any fluid injected into the skin must be surgically removed within a few hours or gangrene may result. Failure to comply could result in serious injury, paralysis or even death.

Maintenance Safety

DO NOT weld on or near rotating parts. Welding close to rotating parts will cause warping and will challenge the structural integrity.

DO NOT weld on or near rotating parts. Welding close to rotating parts may cause warping thus creating high stress loads for moving or rotating parts.

Decal Locations

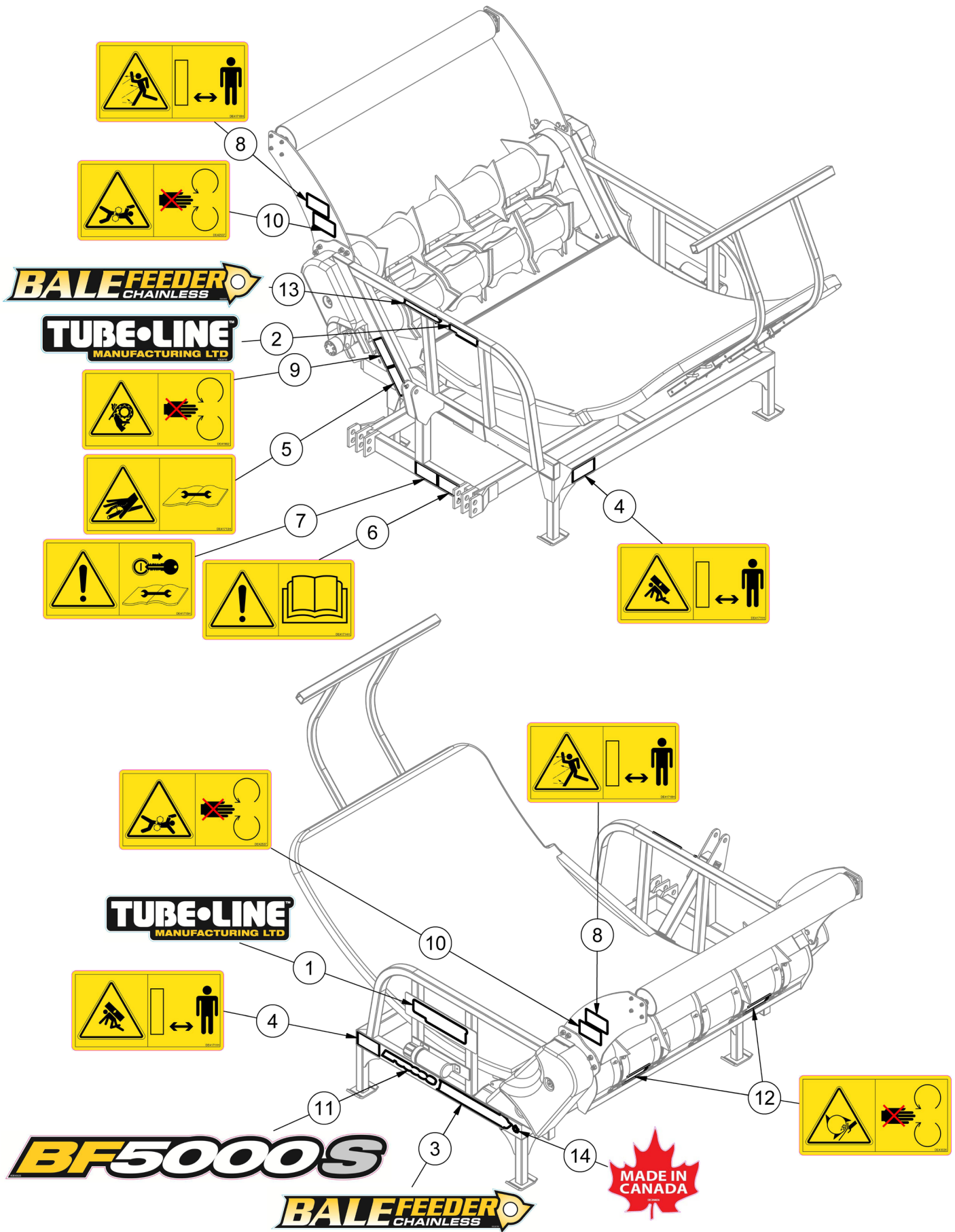

Decal Locations

ITEM	QTY	PART NUMBER	DESCRIPTION
1	1	DE28146	Tubeline Decal 4" x 16"
2	1	DE28705	Tubeline Decal 2.0" x 8.3 "
3	1	DE28708	BaleFeeder Chainless Decal 23 x 4
4	2	DE41711H	ISO Decal - Angled Crush Horizontal
5	1	DE41713H	ISO Decal - High Pressure Fluid Horizontal
6	1	DE41714H	ISO Decal - Read OM Horizontal
7	1	DE41715H	ISO Decal - Remove Key Before Repair Horizontal
8	2	DE41718H	ISO Decal - Thrown Object Horizontal
9	1	DE41902	ISO Decal - Chain Entanglement
10	2	DE42537	ISO Decal Roller Entanglement
11	1	DE43023	BF5000S Model Decal 16 x 2
12	2	DE43026	ISO Shear Point Decal
13	1	DE43055	BaleFeeder Chainless Decal 11.5 x 2
14	1	DECANADA	Decal Made In Canada

Safety Decals

DE41711H - Crush hazard from lowering bed.
Stand clear of machine while operating and
store bed in lowered position.

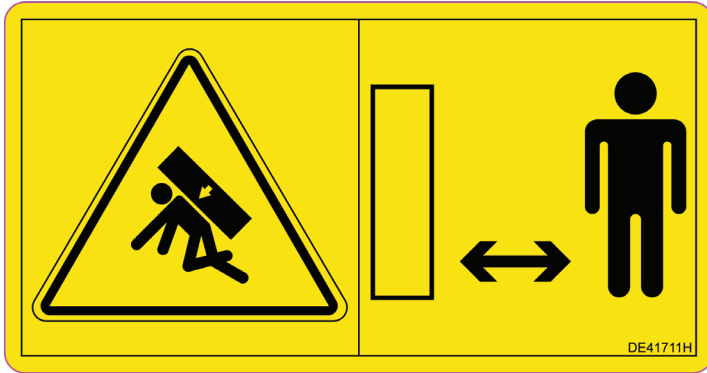

DE41713H - Hydraulic pressure puncture hazard.
Read manual maintenance section before
repairing.

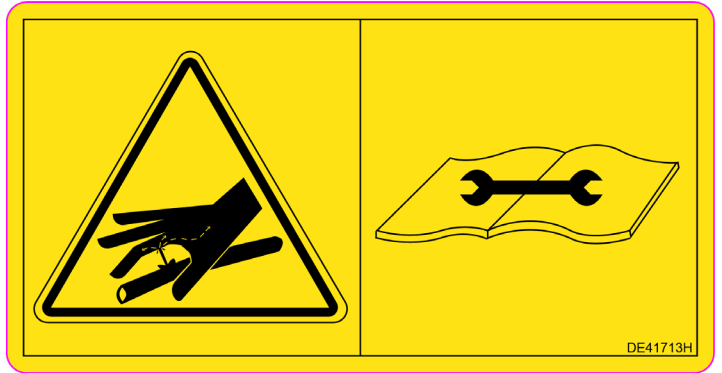

DE41714H - Read Manual Before
Operating Machine.

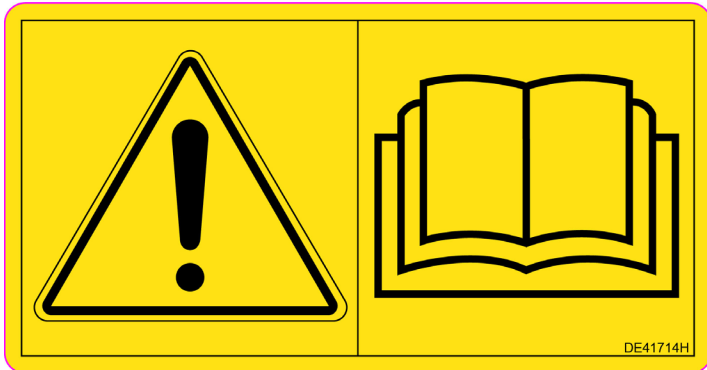

DE41715H - Remove key from power unit
and read manual maintenance section before
attempting repairs.

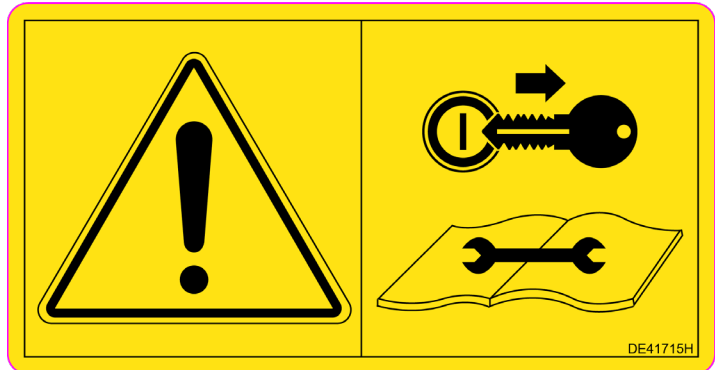

DE41718H - Thrown object hazard.
Be sure all observers are clear of discharge
area while operating.

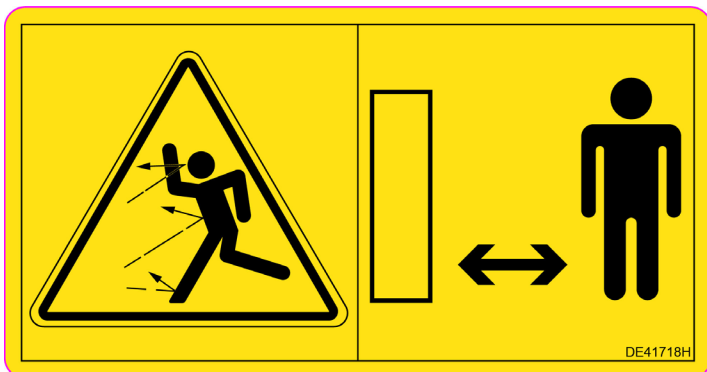

DE41902 - Chain entanglement hazard.
Keep hands clear and shields in place while
operating machine.

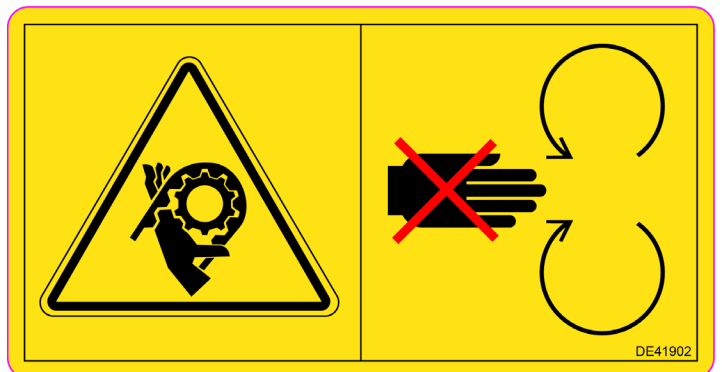

Safety Decals

DE43026 - Beater entanglement hazard.
Keep hands clear and shields in place while operating machine.

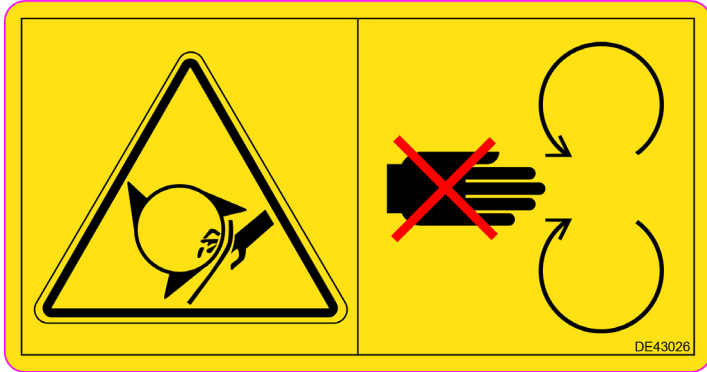

DECANADA - This product is proudly manufactured in Canada.



Model Decals

DE28146 - Manufacturer logo decal (16.5" x 4") & DE28705 - Manufacturer logo decal (8.5" x 2").



DE28708 - Chainless Balefeeder decal (23" x 4") &
DE43055 - Chainless Balefeeder decal (11.5" x 2").



DE43023 - BF5000S model decal (16" x 2").



Section 3: Pre-Operation

Initial Setup

A standard BF5000S ships from the factory fully assembled. It is recommended to complete a full inspection of all moving parts upon delivery before operating. Optional features may also be shipped separately and need to be installed. All needed fasteners are provided by manufacturer.

Optional Bale Bumper Installation

To install the optional bale bumper:

1. Secure two BF5000-260 bumper plates (A) to top of frame on either side of machine using four 5/8" x 1.75" hex bolts and 5/8" lock nuts per side.
2. Slide the two flange bearings (B) onto either side of BF5000-A20 bumper roller's shaft (C).
3. Fasten the two flange bearings with four 7/16" x 1.5" bolts and 7/16" lock nuts to inside face of bumper plates.

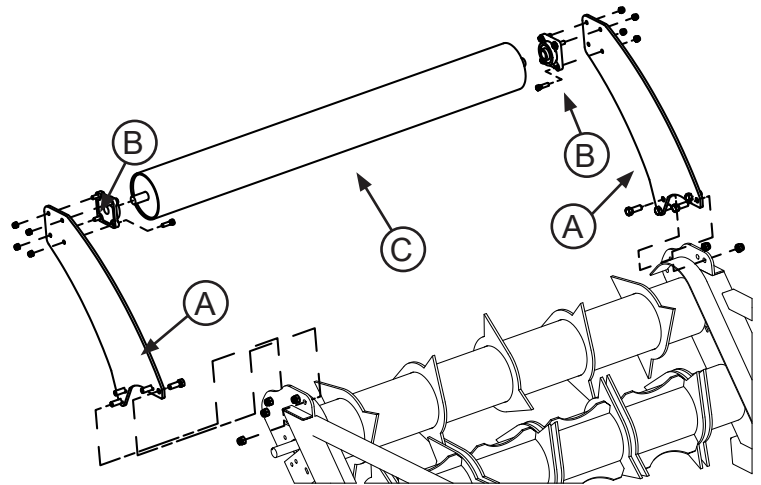

Optional Bale Extension Installation

1. Slide bale extension (A) tube ends into tube holders (B) located on underside of bed frame.
2. Align holder holes and bale extension holes to desired position.
3. Secure in place with four BF5000-238 pins (C) and 1/8" x 1.5" hair pins.

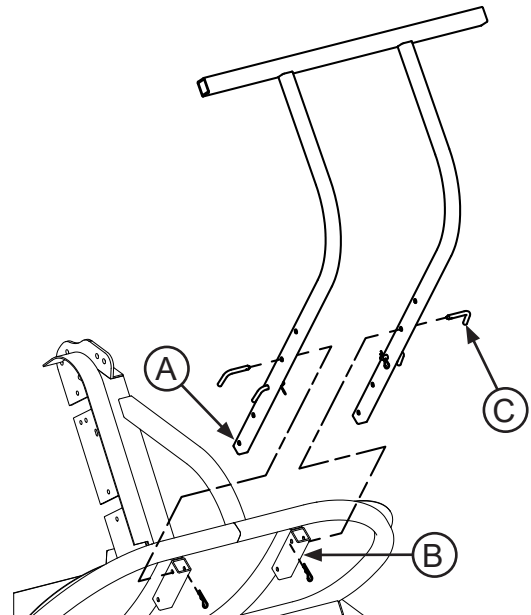

Power Unit Hookup



WARNING: Make sure to apply the park brake before leaving the tractor. Death or serious injury could result if tractor moves.

1. Reverse tractor, aligning 3 point hitch arms (**A**) with Tubeline Bale Feeder hook up holes (**B**).
2. Insert 3 point hitch pins (**C**) through BF5000S hookup holes and fasten.
3. Connect 4 hydraulic quick couplers (**D**) to power unit hydraulic outlets.
4. Make sure parking brake is released before driving away.

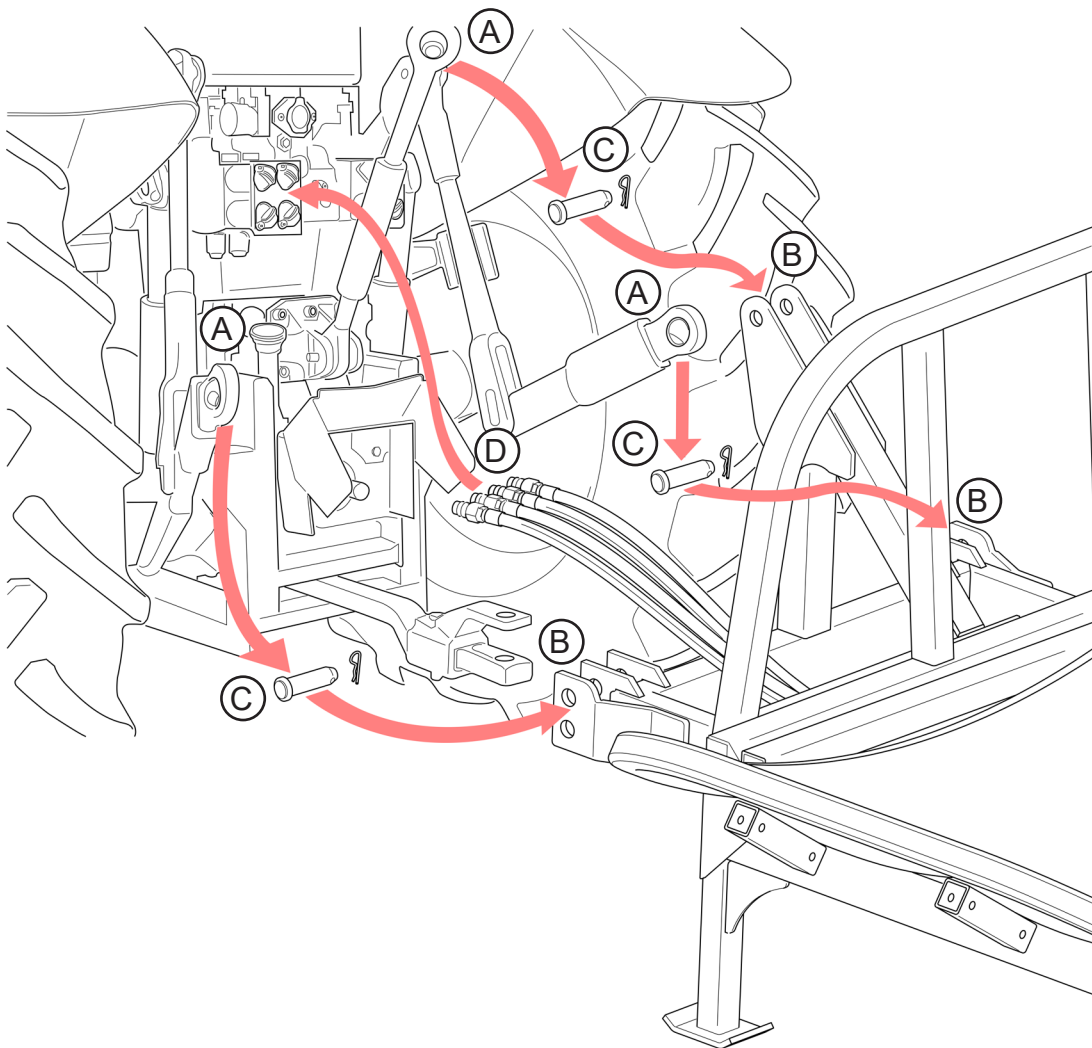

Transporting

1. Check local road laws before transporting.
2. Do a complete walk-around visual check to be sure there are no loose parts or components.
3. Do a visual check of all hoses to make sure they are securely tied so they will not pinch or drag during transporting.
4. When transporting the Tubeline Bale Feeder on the road be aware of the width and length of the Tubeline Bale Feeder, especially when transporting a square bale.
5. Do not transport the machine at night, at dawn, or at dusk.

Speed Limit

Do not exceed 32kph (20mph) during transport.

Section 4: Adjustments

Beater Guide

1. Loosen 5/16-18 bolt (1), and 5/16-18 nuts.

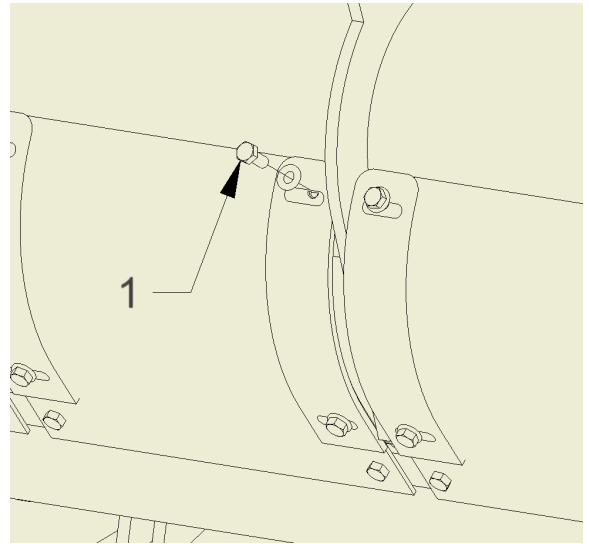

2. Adjust slot opening guide to 1/16" from beater.

3. Retighten fasteners.

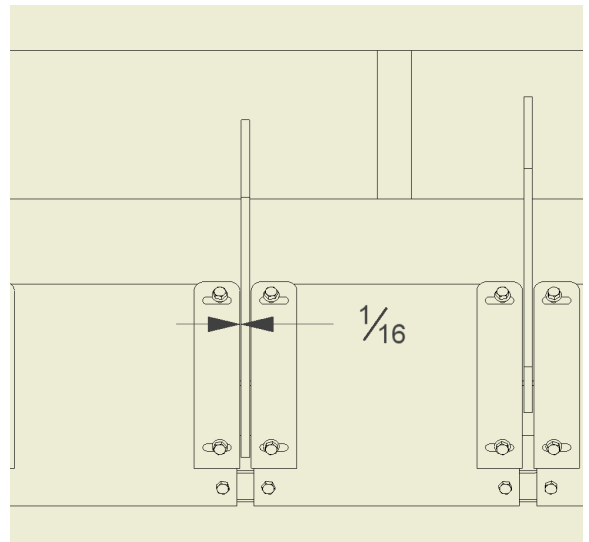

Section 5: Operation

Loading Bales

After attaching the BF5000S to the power unit as specified in [Power Unit Hookup, Pg.3-2](#):

1. Apply hydraulic oil pressure from the power unit to the balefeeder.
2. Confirm that hydraulic lines are not leaking by using power unit controls to raise and lower the balefeeder bed.
3. Use separate loading machine to lift bale off the ground and remove any covering the bale may have.

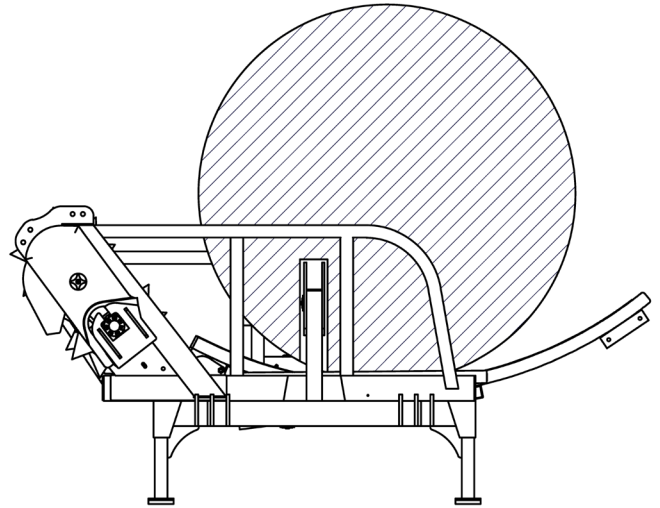

DANGER: Do not attempt to remove cover from underneath raised bale!

4. Set the bale onto the balefeeder bed.
5. Cut baling twine and remove from bale. Bale twine can wrap around rollers and cause damage and or operational failure over time if left on bales.

Feeding

When a bale is securely on the loading bed and the loading arm fully lowered, feeding operation can begin:

1. Use the power unit's hydraulic controls to raise the bed 6 inches (15cm).
2. Start the rollers with power unit hydraulic controls. Reverse the flow direction if rollers do not turn counter-clockwise.
3. Raise the bed until the bale contacts the rollers and starts to turn.
4. Keep raising the bed steadily until the bale completely unravels over the rollers.

NOTE: Bales feed best when allowed time to unravel and flow over the beaters. If the bed is raised too quickly the bale can ride up and either refuse to unroll or plug the rollers. Simply lower the bed until bale lowers and raise bed at a slower pace if this occurs.

NOTE: Wet hay or straw won't unravel nicely. If several biscuits are peeling off the bale together, lower the platform slightly and/or reverse the rollers 2 turns the forward 4 turns, reverse.

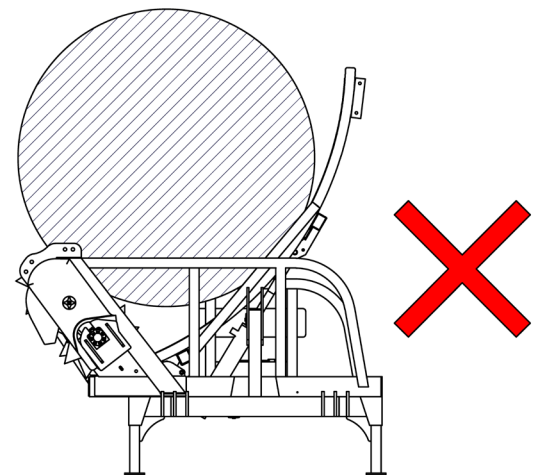
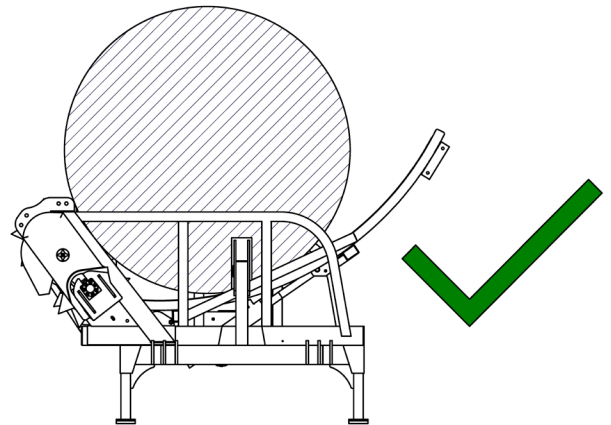

Section 6: Maintenance

This section gives full details of the procedures necessary to maintain the Tubeline Stationary Bale Feeder at peak efficiency. Complete all checks and services in this section at the hour interval shown.

Note: Failure to complete the required maintenance at the interval shown can cause unnecessary downtime.

The recommended lubrication intervals are for average conditions. Perform lubrication more often when operating under adverse conditions.



WARNING

Before lubricating the BF5000S Bale Feeder always observe the following precautions:

Turn off tractor, set parking brake, remove key and wait for all moving parts to stop before leaving cab. Failure to comply could result in death or serious injury.

Grease Point - Beater Bearings

Apply 3 strokes of grease every 50 hours at point (2) (4 locations).

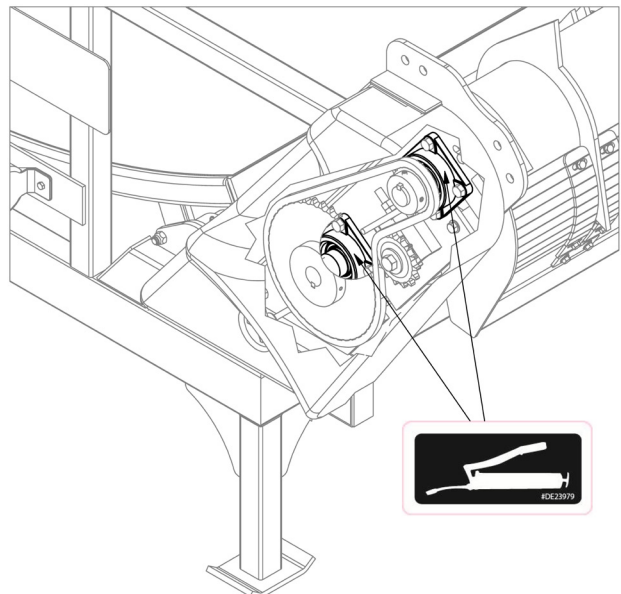
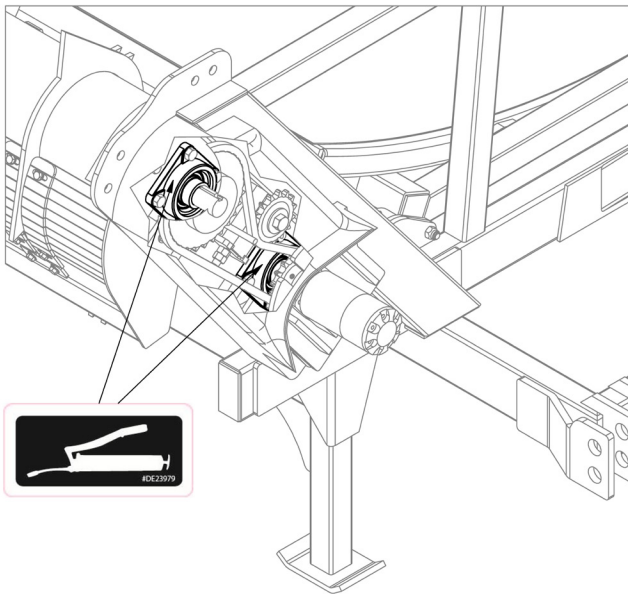

Grease Point - Cylinder Pivot

Apply 3 strokes of grease every 50 hours at point
(4) (4 locations).

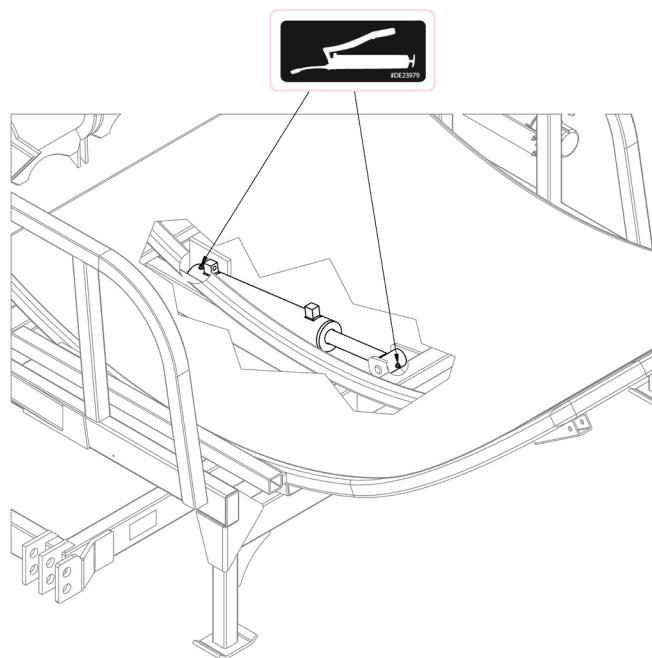

Grease Point - Bale Bumper Bearing (if equipped)

Apply 3 strokes of grease every 50 hours at point
(6) (2 locations).

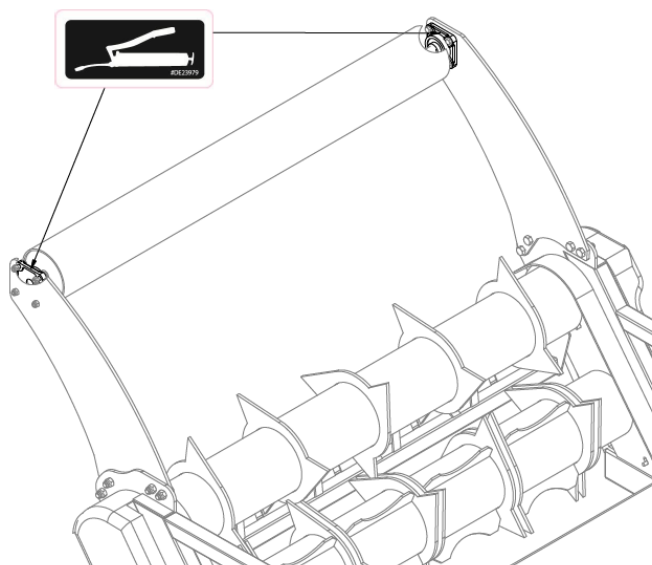

Complete all checks and services in this section at the hour interval shown.

NOTE: Failure to complete the required maintenance at intervals shown can cause unnecessary downtime.

General checking of bolts, security pins and split pins must be carried out initially after the first 8 hours of use. Subsequently, check every 50 hours and whenever the machine is laid up for extended periods.



WARNING

Before performing any adjustments or maintenance on the Tube-Line, observe these safety precautions:

Turn off tractor, set parking brake, remove key and wait for all moving parts to stop before leaving cab.

Read *Maintenance Safety, pg.2-2*.

Failure to comply could result in death or serious injury.

Daily Maintenance

Careful inspection and service of the Bale Feeder prior to operation each day will prevent needless breakdowns and delays in the field. Make the following checks and adjustments.

1. Be alert for loose hardware and tighten or replace as required.
2. Lubricate the BF5000S according to the instruction in the “Lubrication” section of this manual.

Preseason Service

Prior to beginning the harvest after offseason storage, take the following steps be certain the Tube-line BF5000S is in good condition.

Check slot opening guide, make sure it is tight and that the beater blades are clear.

Refer to *Beater Guide, pg.4-2*.

Lubricate the Tube-line BF5000S according to *Grease Points, pg.6-1*.

Tighten or replace any damaged or missing fasteners.

End of Season Service

Prior to storing the Tube-line BF5000S during the off season, follow these steps to ensure easier preparation for the next season and longer Tube-line BF5000S life.

- Pack all grease points with grease. Refer to *Grease Points, pg.6-1*.
- Remove all crop material from the BF5000S.

Section 7: Troubleshooting

Round Bale Problems

Problem: The rotors turn, but the bale refuses to turn.

Cause: The platform is not raised high enough.

Remedy : Raise bed to push bale against both beaters. Refer to [Feeding, pg.5-2](#).

Problem: Several biscuits coming out at once.

Cause: The bed is too high.

Remedy: Lower the bed. The crop material was baled when wet, reverse beaters 2 turns then forward again. Refer to [Feeding, pg.5-2](#).

Square Bale Problems

Problem: Crop material jams between top beater and wiper.

Cause: Too much gap between beater blade guides.

Remedy: Adjust wiper guides. Refer to [Beater Guide, pg.4-2](#).

Intentionally Left Blank

Section 8: Parts Breakdowns & Lists

Illustrations may differ slightly from actual machine.

Front Chain Drive

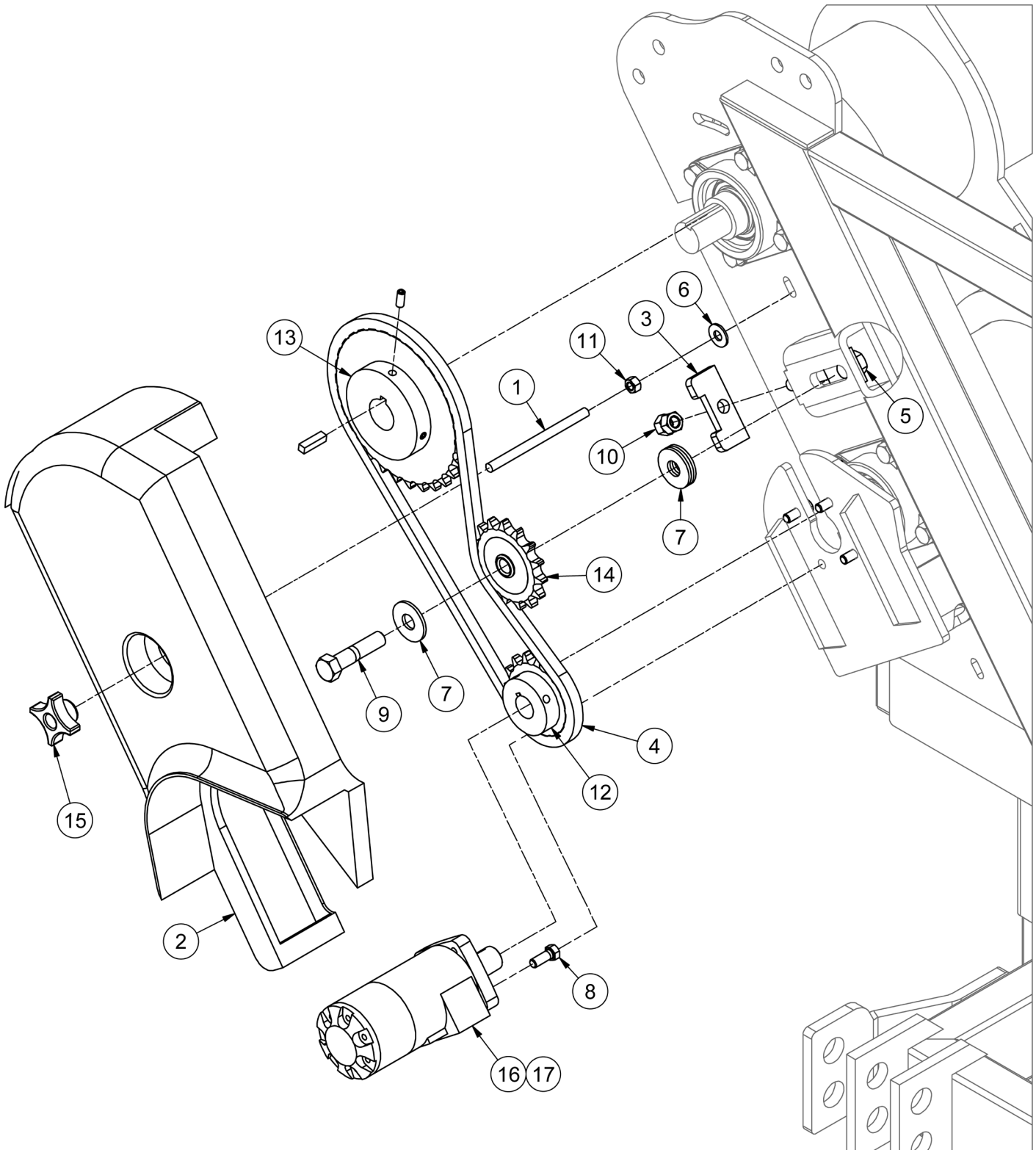

Front Chain Drive

ITEM	QTY	PART NUMBER	DESCRIPTION
1	1	BF5000-106	Tightener Rod
2	1	BF5000-108	Bale Feeder Small Guard
3	1	BF5000-246	Chain Tightener Bracket
4	1	BF5000-254	Chain #60H Roller - 28.5 Links
5	1	BF5000-A17	Slide
6	1	FW 3/8	Flatwasher - 3/8" Zinc Plated USS
7	4	FW 5/8	Flatwasher - 5/8" Zinc Plated USS
8	4	HB3/8-16X1Z5	Hex Bolt 3/8-16x1 Grade 5 Zinc Plated Hex Cap Screw
9	1	HB5/8-11X2.75Z5	Hex Bolt 5/8-11x2 3/4 Grade 5 Zinc Plated Hex Cap Screw
10	2	HN1/2-13CZ5	Hex Nut 1/2"-13 Grade 5 Zinc Plated Finished
11	1	HN3/8-16CZ5	Hex Nut 3/8"-16 Grade 5 Zinc Plated Finished
12	1	SPR60B15-1	Sprocket 60B15 1.0 Bore Idler 1/4 Keyway- 2 Set Screws
13	1	SPR60B30F-1.38	60B30F 1-3/8" KW 2SS 5/16 Keyway
14	1	SRP60A15	Sprocket 60B15 5/8 Bore Idler
15	1	TL599-100-104	Switch Adjuster Screw (4 Prong Knob)
16	1	VAL 1008	Motor, Hydraulic - EAT101-1008-009
17	1	SKMLHPQUDE	Seal Kit for 200 & 400 Series Motors (for MLHPQ-U/D)

Rear Chain Drive

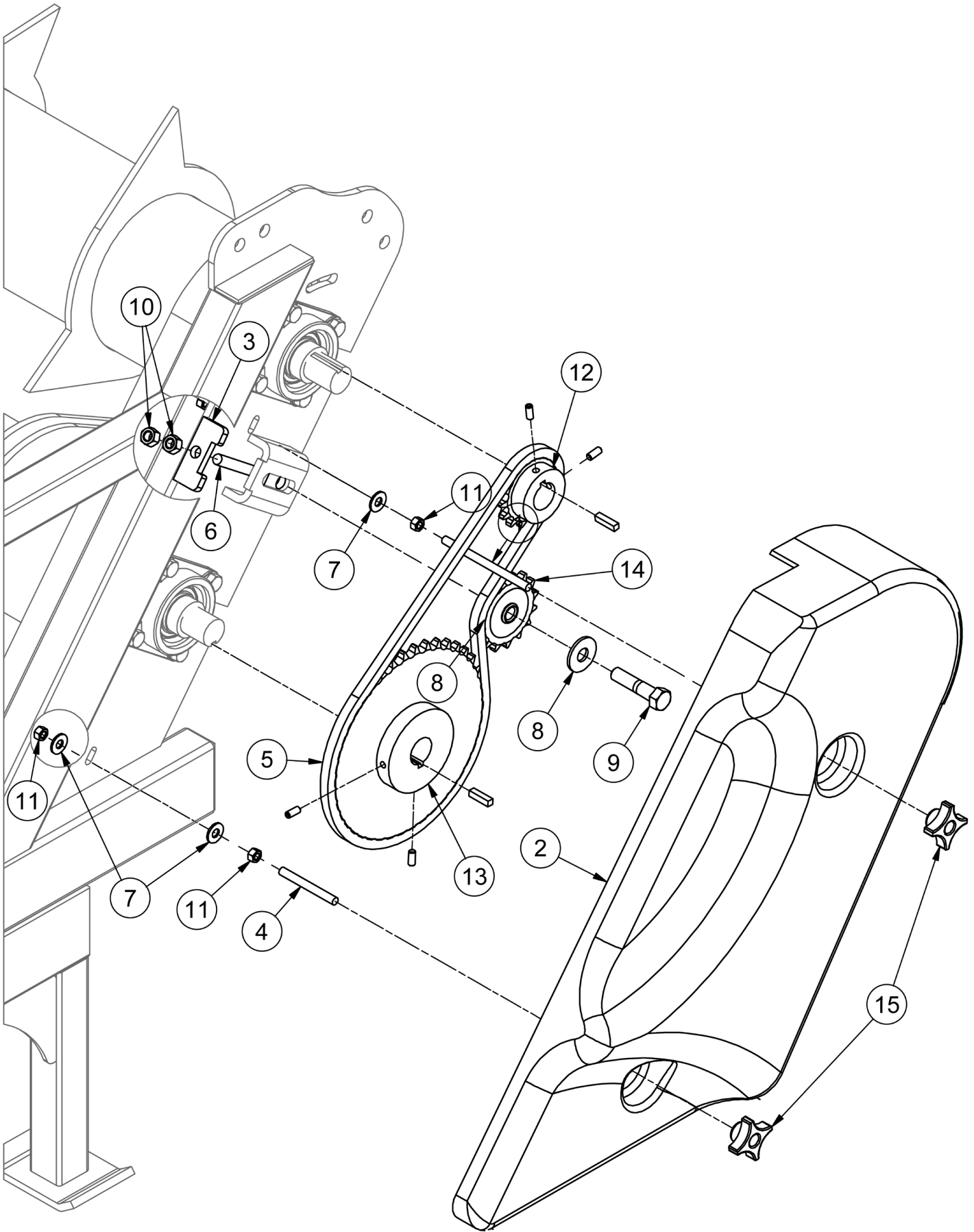

Rear Chain Drive

ITEM	QTY	PART NUMBER	DESCRIPTION
1	1	BF5000-106	Tightener Rod
2	1	BF5000-109	Bale Feeder Large Guard
3	1	BF5000-246	Chain tightener Bracket
4	1	BF5000-250	Bottom Tightener Rod
5	1	BF5000-255	Chain #60H - 32 Links
6	1	BF5000-A17	Slide
7	4	FW 3/8	Flatwasher - 3/8" Zinc Plated USS
8	4	FW 5/8	Flatwasher - 5/8" Zinc Plated USS
9	1	HB5/8-11X2.75Z5	Hex Bolt 5/8-11x2 3/4 Grade 5 Zinc Plated Hex Cap Screw
10	2	HN1/2-13CZ5	Hex Nut 1/2"-13 Grade 5 Zinc Plated Finished
11	4	HN3/8-16CZ5	Hex Nut 3/8"-16 Grade 5 Zinc Plated Finished
12	1	SPR60B15-1.38	60B15- 1.38 Bore 5/16 KW & Set Screw
13	1	SPR60B42F-1.38	Sprocket - 60B42F 1 3/8" KW 2SS 5/16 Keyway
14	1	SRP60A15	Sprocket 60B15 5/8 Bore Idler
15	2	TL599-100-104	Switch Adjuster Screw (4 Prong Knob)

Beaters

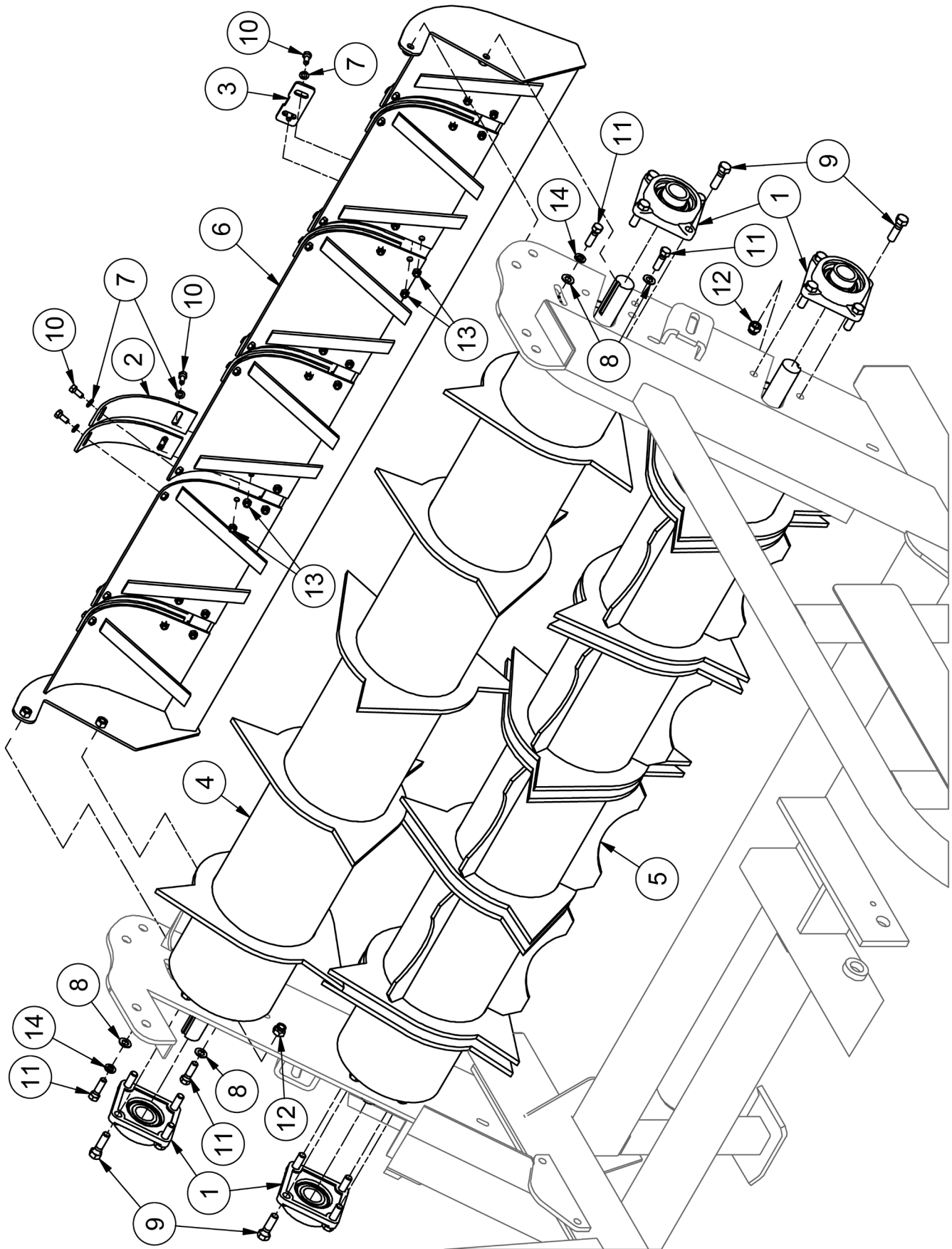

Beaters

ITEM	QTY	PART NUMBER	DESCRIPTION
1	4	BEA UCF207-22	Flange Block, UCF207-22 1.38" Diameter, National 4-Bolt
2	10	BF5000-100	Slot Opening Guide
3	5	BF5000-101	HRP .188
4	1	BF5000-A01	Top Drum
5	1	BF5000-A02	Bottom Drum
6	1	BF5000-A18	Small Wiper
7	30	FW 5/16	Flatwasher - 5/16" Zinc Plated USS
8	4	FW 7/16	Flatwasher - 7/16" Zinc Plated USS
9	16	HB1/2-13X1.75Z5	Hex Bolt 1/2-13x1 3/4 Grade 5 Zinc Plated Hex Cap Screw
10	30	HB5/16-18X0.75Z5	Hex Bolt 5/16-18x3/4 Grade 5 Zinc Plated Hex Cap Screw
11	4	HB7/16-14X1.5Z5	Hex Bolt 7/16-14x1 1/2 Grade 5 Zinc Plated Hex Cap Screw
12	16	LN1/2-13NCZ5	LN 1/2-13 Zinc Plated Nylon Insert Lock Nut
13	20	LN5/16-18NCZ5	LN 5/16-18 Zinc Plated Nylon Insert Lock Nut
14	2	LW 7/16	LW - 7/16" Zinc Plated Medium Split

Bed

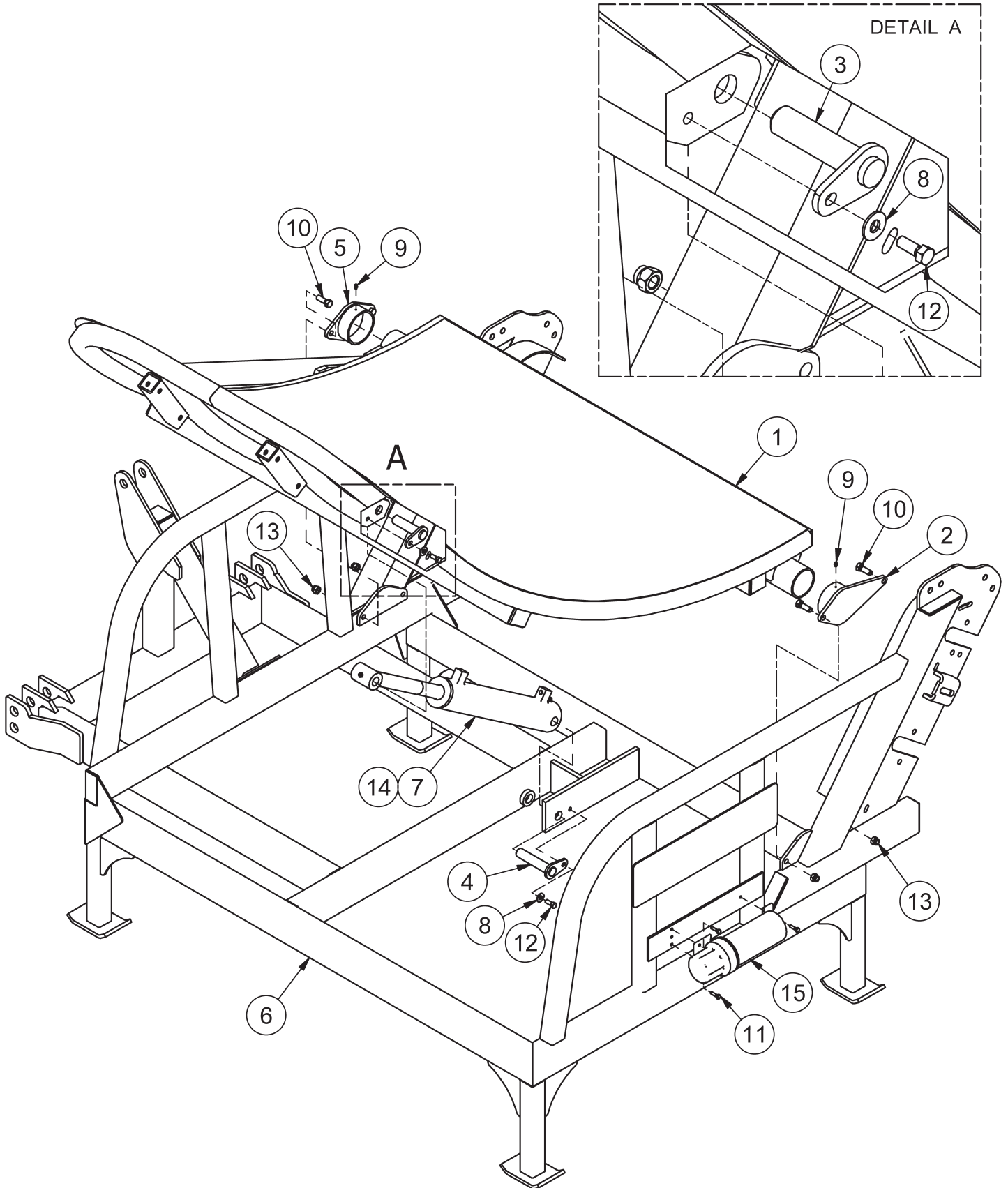

Bed

ITEM	QTY	PART NUMBER	DESCRIPTION
1	1	BF5000-06B	Bed Assembly
2	1	BF5000-22b	Pivot Tab
3	1	BF5000-A14	Bed Cylinder Pin
4	1	BF5000-A15	Frame Cylinder Pin
5	1	BF5000-A21B	Pivot Tab
6	1	BF5000-S-01B	Frame
7	1	CYL 30014	Hydraulic Cylinder - 3" X 14" X 1.5"
8	2	FW 3/8	Flatwasher - 3/8" Zinc Plated USS
9	2	GR 3/16D	3/16 Drive Straight Grease Fitting
10	4	HB1/2-13X1.5Z5	Hex Bolt 1/2-13x1 1/2 Grade 5 Zinc Plated Hex Cap Screw
11	3	HB1/4-20X1Z5	Hex Bolt 1/4-20x1 Grade 5 Zinc Plated Hex Cap Screw
12	2	HB3/8-16X1Z5	Hex Bolt 3/8-16x1 Grade 5 Zinc Plated Hex Cap Screw
13	4	LN1/2-13NCZ5	LN 1/2-13 Zinc Plated Nylon Insert Lock Nut
14	1	SK 03-14AG	Seal Kit for 3" Cylinder (Frankor) Cylinder 300401
15	1	TL5X2-201-111	Operator's Manual Holder

Hydraulic Layout

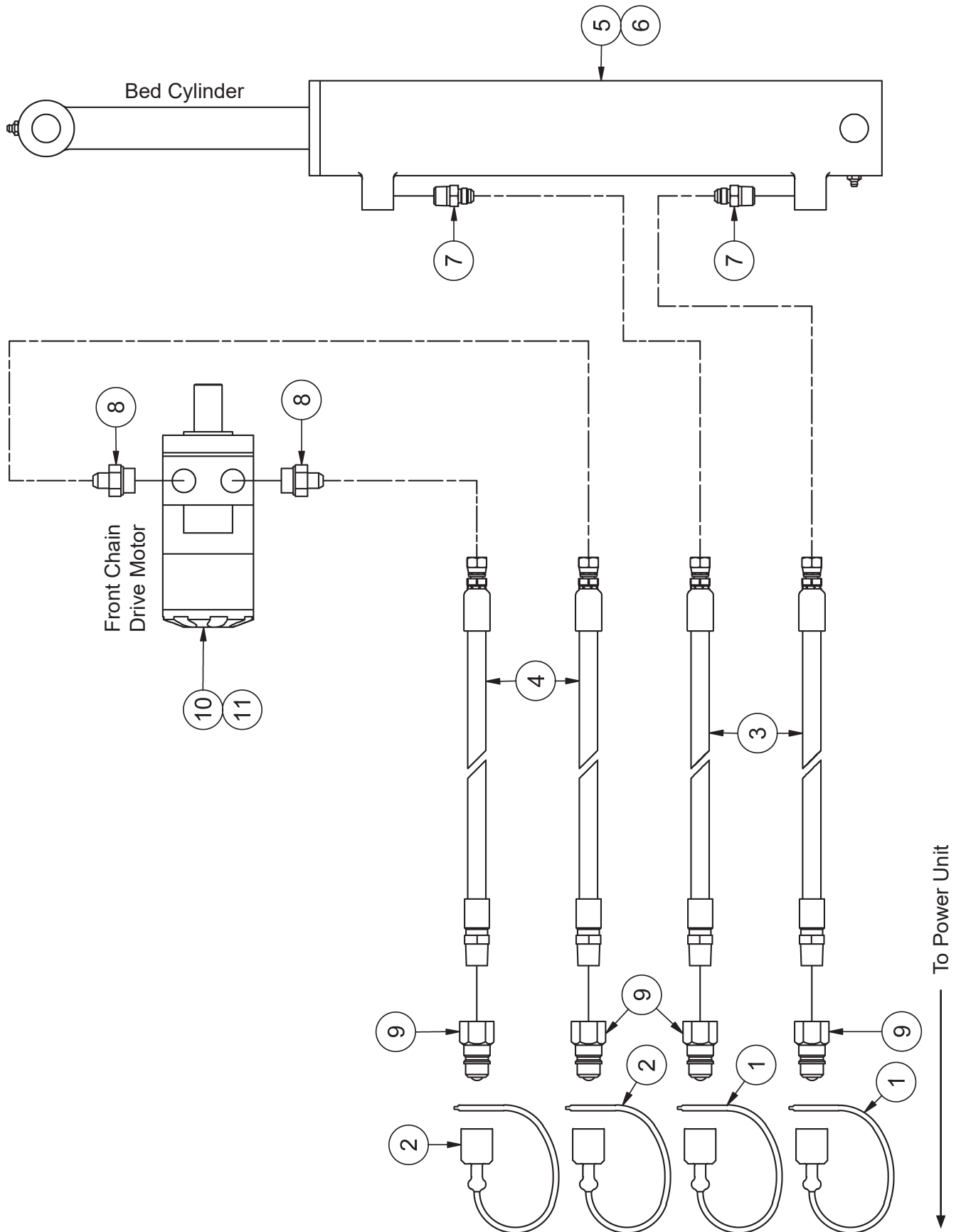

Hydraulic Layout

ITEM	QTY	PART NUMBER	DESCRIPTION
1	2	22946-2	Dust Cap, 1/2", Female, Yellow Colour
2	2	22946-3	Dust Cap, 1/2", Female, Blue Colour
3	2	32850	HH120 - 6AT1(6FJX,8MP) HCL 120"
4	2	32851	HH92 - 6AT1(6FJX,8MP) HCL 92"
5	1	CYL 3001401	Hydraulic Cylinder - 3" X 14" X 1.5"
6	1	SK 03-14GA	Seal Kit for 3" Cylinder (Frankor) Cylinder 300401
7	2	HF 2404-6-6	Hyd. Fitting, 3/8 M-Pipe to 3/8 M-JIC
8	2	HF 6400-6-10	Hydraulic Fitting - Male JIC - Male ORB
9	4	HF 8010-4	Quickcoupler 1/2" Male Tip
10	1	VAL 1008	Motor, Hydraulic - EAT101-1008-009
11	1	SKMLHPQUDE	Seal Kit for 200 & 400 Series Motors

Section 9: Options

BF-RBB - Bale Bumper

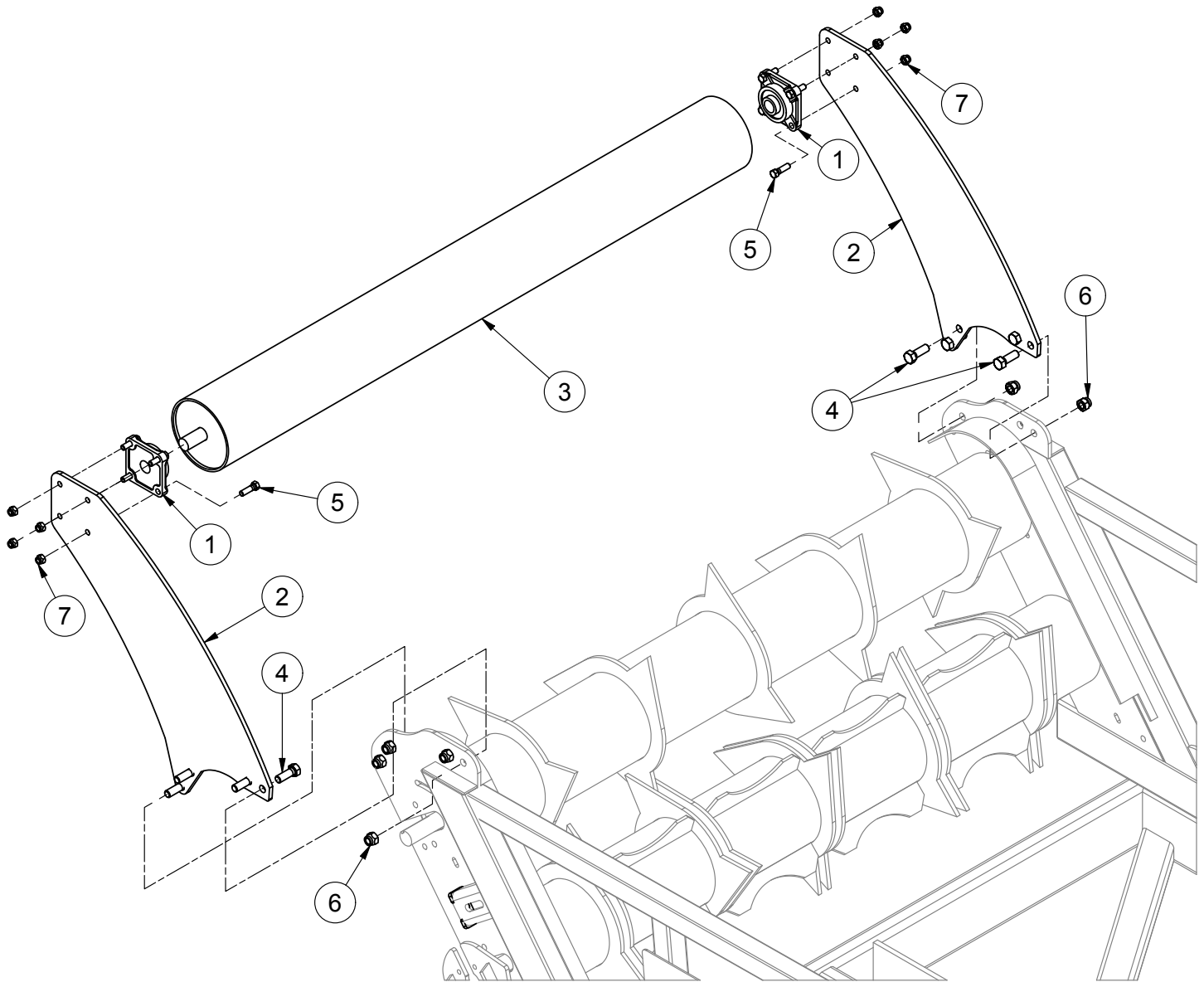

BF-RBB - Bale Bumper

ITEM	QTY	PART NUMBER	DESCRIPTION
1	2	BEA UCF206-18	Flange Block, UCF206-18 National 4-Bolt 1.12" Bearing
2	2	BF5000-260	Bumper Plate
3	1	BF5000-A20	Bumper Roller
4	8	HB 5/8-11X1.75 Z5	Hex Bolt 5/8-11x1 3/4 Grade 5 Zinc Plated Hex Cap Screw
5	8	HB 7/16-14X1.5 Z5	Hex Bolt 7/16-14x1 1/2 Grade 5 Zinc Plated Hex Cap Screw
6	8	LN 5/8 N	LN 5/8-11 Zinc Plated Nylon Insert Lock Nut
7	8	LN 7/16 N	LN 7/16-14 Zinc Plated Nylon Insert Lock Nut

BF-SBEX60 - Bale Extension

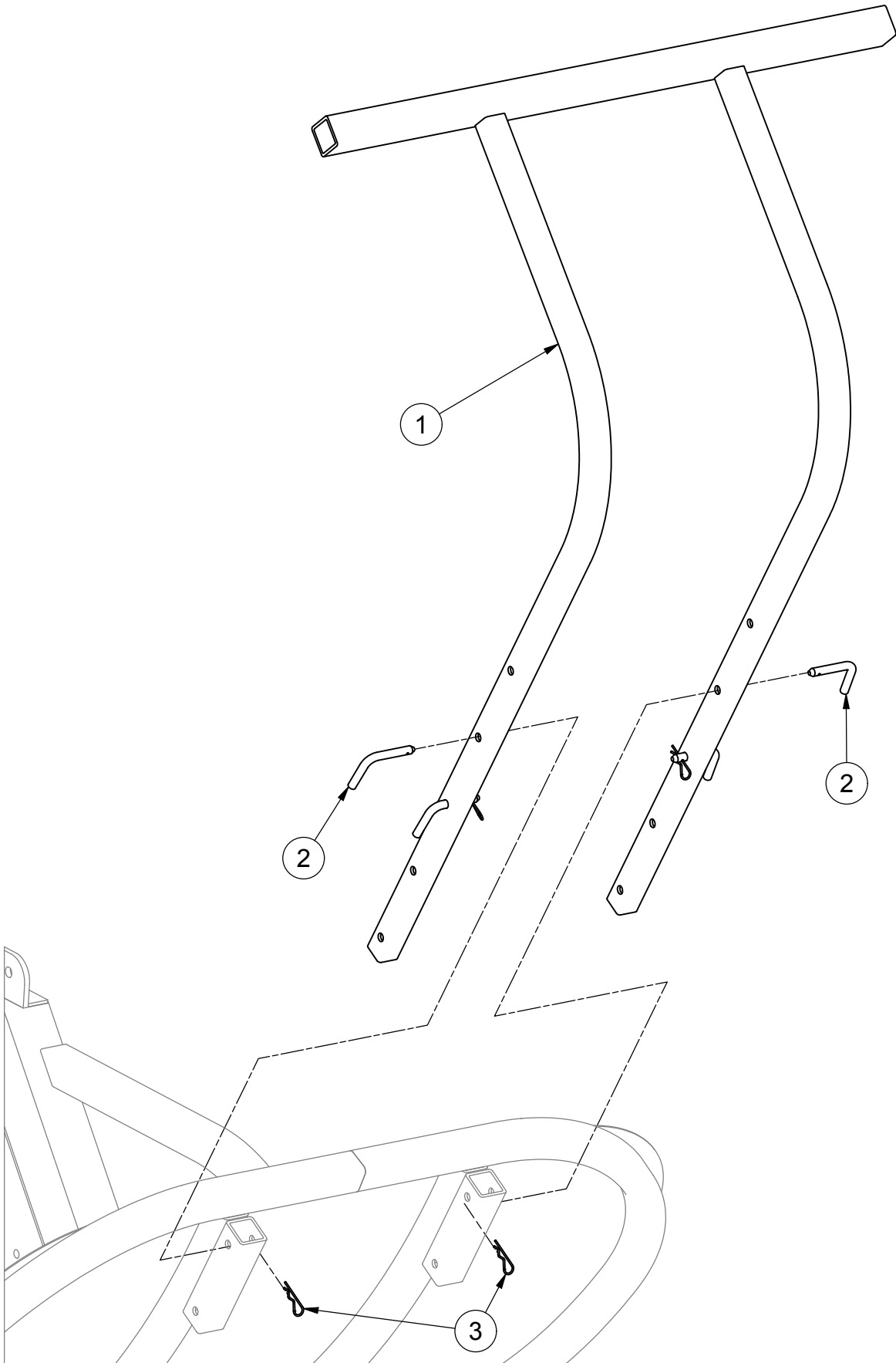











BF-SBEX60 - Bale Extension

ITEM	QTY	PART NUMBER	DESCRIPTION
1	1	BF5000-A10	Bale Extension
2	4	BF5000-238	Bale Extension Pin
3	4	HP .125X1.5	Pin Hitch - .125 X 1.5

Torque Values - Imperial

UNIFIED INCH BOLT AND CAP SCREW TORQUE VALUES

SAE Grade and Head Markings	1 or 2 ^b	5	5.1	5.2	8	8.2
	NO MARK 					
SAE Grade and Nut Markings	2	5		8		
	NO MARK 					

TS1162 -19-03M4181

Size	Grade 1				Grade 2 ^b				Grade 5, 5.1, or 5.2				Grade 8 or 8.2			
	Lubricated ^a		Dry ^a		Lubricated ^a		Dry ^a		Lubricated ^a		Dry ^a		Lubricated ^a		Dry ^a	
	N-m	lb-ft	N-m	lb-ft	N-m	lb-ft	N-m	lb-ft	N-m	lb-ft	N-m	lb-ft	N-m	lb-ft	N-m	lb-ft
1/4	3.7	2.8	4.7	3.5	6	4.5	7.5	5.5	9.5	7	12	9	13.5	10	17	12.5
5/16	7.7	5.5	10	7	12	9	15	11	20	15	25	18	28	21	35	26
3/8	14	10	17	13	22	16	27	20	35	26	44	33	50	36	63	46
7/16	22	16	28	20	35	26	44	32	55	41	70	52	80	58	100	75
1/2	33	25	42	31	53	39	67	50	85	63	110	80	120	90	150	115
9/16	48	36	60	45	75	56	95	70	125	90	155	115	175	130	225	160
5/8	67	50	85	62	105	78	135	100	170	125	215	160	240	175	300	225
3/4	120	87	150	110	190	140	240	175	300	225	375	280	425	310	550	400
7/8	190	140	240	175	190	140	240	175	490	360	625	450	700	500	875	650
1	290	210	360	270	290	210	360	270	725	540	925	675	1050	750	1300	975
1-1/8	400	300	510	375	400	300	510	375	900	675	1150	850	1450	1075	1850	1350
1-1/4	570	425	725	530	570	425	725	530	1300	950	1650	1200	2050	1500	2600	1950
1-3/8	750	550	950	700	750	550	950	700	1700	1250	2150	1550	2700	2000	3400	2550
1-1/2	1000	725	1250	925	990	725	1250	930	2250	1650	2850	2100	3600	2650	4550	3350

DO NOT use these values if a different torque value or tightening procedure is given for a specific application. Torque values listed are for general use only. Check tightness of fasteners periodically.

Shear bolts are designed to fail under predetermined loads. Always replace shear bolts with identical grade.

^a "Lubricated" means coated with a lubricant such as engine oil, or fasteners with phosphate and oil coatings. "Dry" means plain or zinc plated without any lubrication.

^b Grade 2 applies for hex cap screws (not hex bolts) up to 152 mm (6-in.) long. Grade 1 applies for hex cap screws over 152 mm (6-in.) long, and for all other types of bolts and screws of any length.

Fasteners should be replaced with the same or higher grade. If higher grade fasteners are used, these should only be tightened to the strength of the original.

Make sure fasteners threads are clean and that you properly start thread engagement. This will prevent them from failing when tightening.

Tighten plastic insert or crimped steel-type lock nuts to approximately 50 percent of the dry torque shown in the chart, applied to the nut, not to the bolt head. Tighten toothed or serrated-type lock nuts to the full torque value.

DX.TORQ1 -19-20JUL04

Torque Values - Metric

METRIC BOLT AND CAP SCREW TORQUE VALUES

Property Class and Head Markings	4.8		8.8		9.8		10.9		12.9	
Property Class and Nut Markings	5		10		10		10		12	

Size	Class 4.8				Class 8.8 or 9.8				Class 10.9				Class 12.9			
	Lubricated ^a		Dry ^a		Lubricated ^a		Dry ^a		Lubricated ^a		Dry ^a		Lubricated ^a		Dry ^a	
	N-m	lb-ft	N-m	lb-ft	N-m	lb-ft	N-m	lb-ft	N-m	lb-ft	N-m	lb-ft	N-m	lb-ft	N-m	lb-ft
M6	4.8	3.5	6	4.5	9	6.5	11	8.5	13	9.5	17	12	15	11.5	19	14.5
M8	12	8.5	15	11	22	16	28	20	32	24	40	30	37	28	47	35
M10	23	17	29	21	43	32	55	40	63	47	80	60	75	55	95	70
M12	40	29	50	37	75	55	95	70	110	80	140	105	130	95	165	120
M14	63	47	80	60	120	88	150	110	175	130	225	165	205	150	260	190
M16	100	73	125	92	190	140	240	175	275	200	350	255	320	240	400	300
M18	135	100	175	125	260	195	330	250	375	275	475	350	440	325	560	410
M20	190	140	240	180	375	275	475	350	530	400	675	500	625	460	800	580
M22	260	190	330	250	510	375	650	475	725	540	925	675	850	625	1075	800
M24	330	250	425	310	650	475	825	600	925	675	1150	850	1075	800	1350	1000
M27	490	360	625	450	950	700	1200	875	1350	1000	1700	1250	1600	1150	2000	1500
M30	675	490	850	625	1300	950	1650	1200	1850	1350	2300	1700	2150	1600	2700	2000
M33	900	675	1150	850	1750	1300	2200	1650	2500	1850	3150	2350	2900	2150	3700	2750
M36	1150	850	1450	1075	2250	1650	2850	2100	3200	2350	4050	3000	3750	2750	4750	3500

DO NOT use these values if a different torque value or tightening procedure is given for a specific application. Torque values listed are for general use only. Check tightness of fasteners periodically.

Shear bolts are designed to fail under predetermined loads. Always replace shear bolts with identical property class.

Fasteners should be replaced with the same or higher property class. If higher property class fasteners are used, these should only be tightened to the strength of the original.

^a "Lubricated" means coated with a lubricant such as engine oil, or fasteners with phosphate and oil coatings. "Dry" means plain or zinc plated without any lubrication.

Make sure fasteners threads are clean and that you properly start thread engagement. This will prevent them from failing when tightening.

Tighten plastic insert or crimped steel-type lock nuts to approximately 50 percent of the dry torque shown in the chart, applied to the nut, not to the bolt head. Tighten toothed or serrated-type lock nuts to the full torque value.

Index

Bales	.1-1
Beater Guide	.4-1
Beaters	.8-6
Bed	.8-8
BF-RBB - Bale Bumper	.9-1
BF-SBEX60 - Bale Extension	.9-3
Daily Maintenance	.6-3
Decal Locations	.2-3
Dimensions	.1-1
End of Season Service	.6-3
Feeding	.5-1
Front Chain Drive	.8-2
Grease Point - Bale Bumper Bearing (if equipped)	.6-2
Grease Point - Beater Bearings	.6-1
Grease Point - Cylinder Pivot	.6-2
Hydraulic Layout	8-10
Hydraulic Safety	.2-2
Initial Setup	.3-1
Loading Bales	.5-1
Maintenance Safety	.2-2
Model Decals	.2-6
Operator's Manual	.1
Optional Bale Bumper Installation	.3-1
Optional Bale Extension Installation	.3-1
Orientation	.1-2
Personal Protective Equipment	.2-2
Power Unit Hookup	.3-2
Power Unit Requirements	.1-1
Preseason Service	.6-3
Rear Chain Drive	.8-4
Round Bale Problems	.7-1
Safety Decals	.2-5
Safety Guidelines	.2-1
Safety Signal Words / Safety Messages	.2-1
Section 1: General Information	.1-1
Section 2: Safety	.2-1
Section 3: Pre-Operation	.3-1
Section 4: Adjustments	.4-1
Section 5: Operation	.5-1
Section 6: Maintenance	.6-1
Section 7: Troubleshooting	.7-1
Section 8: Parts Breakdowns & Lists	.8-1
Section 9: Options	.9-1

Serial Number	I
Speed Limit3-3
Square Bale Problems7-1
Terminology1-2
Torque Values - Imperial	10-1
Torque Values - Metric	11-1
Transporting3-3
Usage1-1
Warranty and Limitation of Liability	I
Weight1-1

Intentionally Left Blank

Intentionally Left Blank

TUBE•LINE™